

# Philips Lumiblade OLED driver, mains voltage D230V 80W/0.1-0.5/1A/28V TD/A 8CH

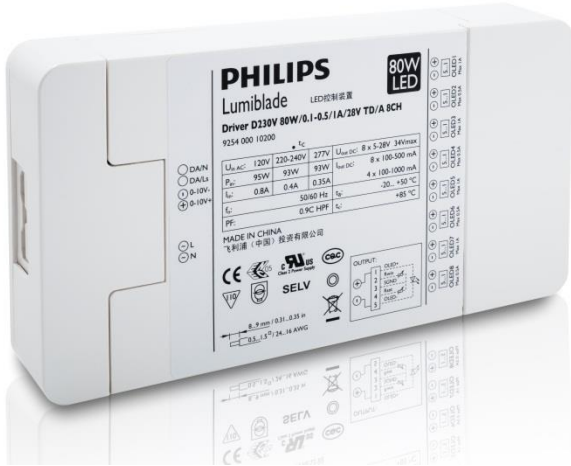

Enabling future proof OLED technology.

This driver detects the power and voltage needs of the attached OLED panel and drives it accordingly.

It is designed for the current range of Lumiblade OLEDs and makes life much easier for customers as one driver fits many different OLEDs. Customers can wire this driver to the most common mains voltages and drive up to eight OLEDs simultaneously.

## Benefits

- Smallest 8-channel OLED driver with mains input in the market.
- One driver for many types of OLEDs.
- Optimized for multi-panel, high-lumen OLED luminaires and installations.

## Product Features

- Universal AC mains input from 120-277 V.
- Nominal output current from 100-500 mA (in 8 channel configuration).
- Nominal output current from 100-1000 mA (in 4 channel configuration).
- Built-in 0-10V, DALI and “Touch and Dim” interface. Dim down to 1% and switch off.
- Implemented short-circuit and over-voltage protection.

## Applications

Retail, Hospitality, Offices and Homes.

## Electrical input data

Specification item	Value	Unit	Condition
Nominal input voltage	120 - 277	V <sub>AC</sub>	
Input frequency range	50-60	Hz	
Maximal input current	0.8	A	Input voltage = 120 V <sub>AC</sub>
	0.4	A	Input voltage = 220-240 V <sub>AC</sub>
	0.35	A	Input voltage = 277 V <sub>AC</sub>
Maximal input power	95	W	Input voltage = 120 V <sub>AC</sub>
	93	W	Input voltage = 220-240 V <sub>AC</sub>
	93	W	Input voltage = 277 V <sub>AC</sub>
Efficiency	85	%	Input voltage = 120 V <sub>AC</sub> @ 80 W output
	83	%	Input voltage = 230 V <sub>AC</sub> @ 80 W output
Recommended number of drivers per MCB 16A, type B circuit breaker	16	pieces	

## Electrical output data

Specification item	Value	Unit	Condition
Regulation method	Constant current, Amplitude dimming technology		
Output voltage	5 ... 28	V <sub>DC</sub>	
Output voltage max	34	V <sub>DC</sub>	Peak voltage at open load
Output current for channel 1, 3, 5 and 7	100 ... 1000	mA	Adjustable by DALI or R <sub>set</sub>
Output current for channel 2, 4, 6 and 8	100 ... 500	mA	Adjustable by DALI or R <sub>set</sub>
Output current tolerance	± 5	%	100% dim level
Output current ripple	30	%	Ripple = (peak to peak) / average
Output power max for channel 1, 3, 5 and 7	20	W	Full output
Output power max for channel 2, 4, 6 and 8	10	W	Full output

**Note:** In case channel 1 is operated at an output current above 500mA, channel 2 is disabled.

This is implemented to guarantee the lifetime of the driver.

This situation is also applicable on the channels 3 and 4, 5 and 6 and 7 and 8.

## Electrical data controls input

Specification item	Value	Unit	Condition
Control Method	“Touch and Dim”, DALI and 0-10V dimming		With switch-off function
Dimming range	1 ... 100	%	
Galvanic isolation	2750	V <sub>AC</sub>	

## Wiring

Specification item	Value	Unit	Condition
Input wire cross-section	0.5 ... 1.5 24 ... 16	mm <sup>2</sup> AWG	WAGO 250-series, solid wire, 2A max.
Input wire strip length	8 ... 9 0.31 ... 0.35	mm inch	
Output connector (Picoblade)	0532610571		Molex PicoBlade
Output connector (Individual wiring)	0.5 ... 1.5 20 ... 16	mm <sup>2</sup> AWG	WAGO 250-series

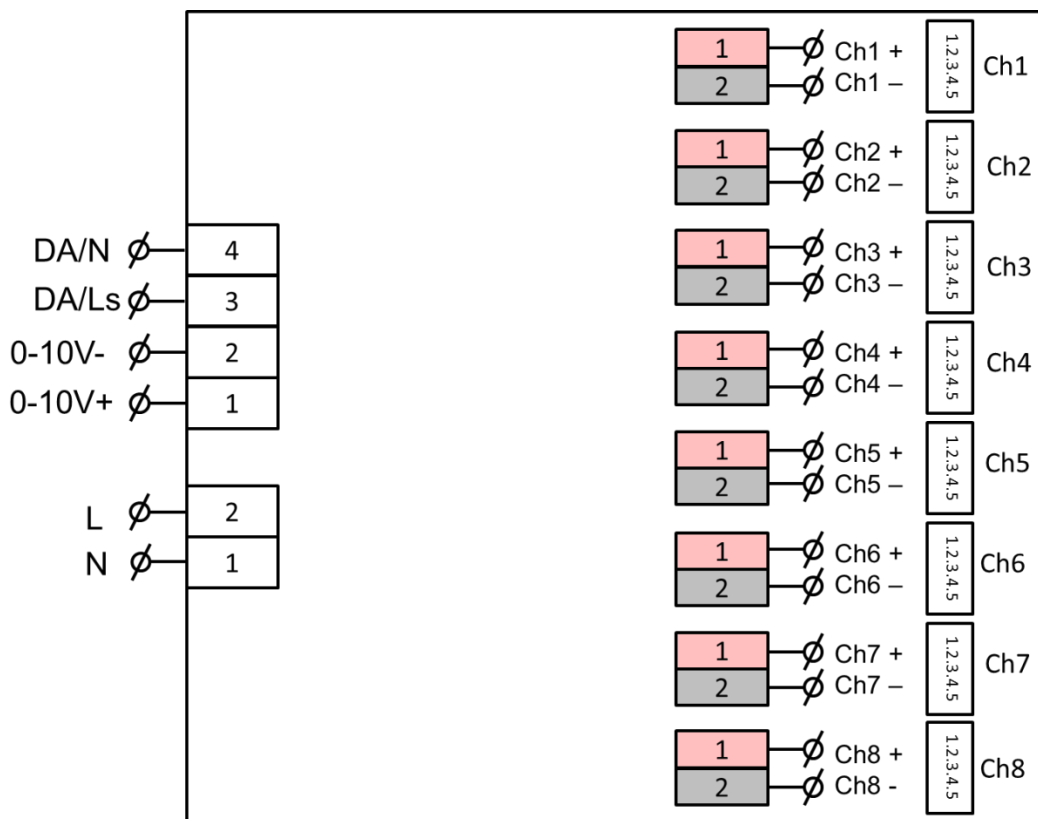

Figure 1: System connections of Driver D230V 80W/0.1-0.5/1A/28V TD/A 8CH

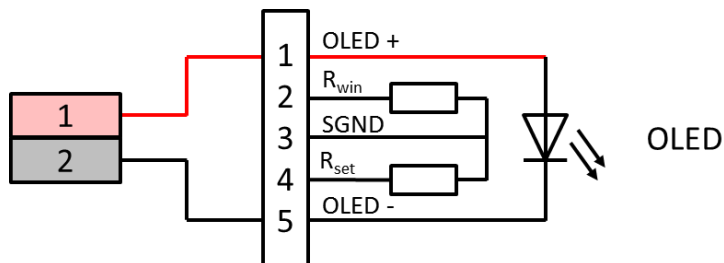

Figure 2: Output Channel connections from Driver D230V 80W/0.1-0.5/1A/28V TD/A 8CH

## Dimensions and weight

Specification item	Value	Unit	Condition
Length	227	mm	
Width	118.5	mm	
Height	36.5	mm	
Fixing hole diameter	4.5	mm	Fixing with M3 screws
Fixing hole distance	190	mm	
Weight	480	gram	

**Note:** The strain reliefs can be closed by means of pre-assembled Philips-head screws. The maximum allowed torque for mounting the screws is 1.0Nm.

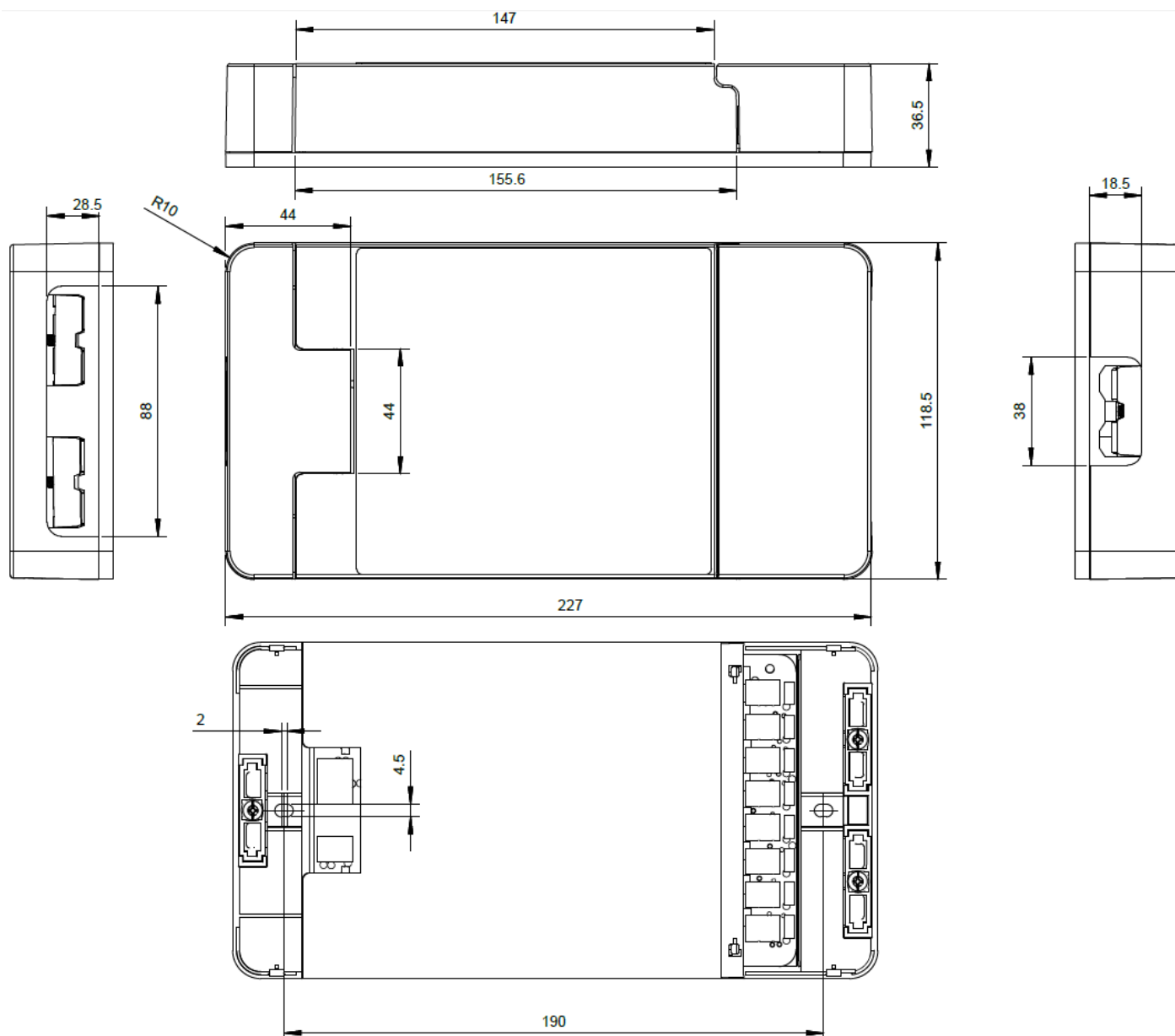

Figure 3: Dimensions of Driver D230V 80W/0.1-0.5/1A/28V TD/A 8CH

## Operational temperature and humidity

Specification item	Value	Unit	Condition
Ambient temperature	-20 ... +50	°C	
T <sub>case-max</sub>	85	°C	Maximum temperature measured at T <sub>c</sub> -point (lifetime reduced by 50%)
T <sub>case-life</sub>	75	°C	Measured at T <sub>c</sub> point
Relative humidity	5 ... 85	%	Non condensing
Internal temperature protection	100	°C	

## Storage temperature and humidity

Specification item	Value	Unit	Condition
Ambient temperature	-25 ... +85	°C	
Relative humidity	5 ... 95	%	Non condensing

## Lifetime

Specification item	Value	Unit	Condition
Driver lifetime	50,000	hours	Measured temperature at T <sub>c</sub> -point is T <sub>case-life</sub> . Maximum failures is 10%

## Features

Specification item	Value	Unit	Condition
Open load protection	Yes		Reset by DALI off or R <sub>SET</sub> /R <sub>WIN</sub> resistor insertion
Short circuit protection	Yes		Reset by DALI off or R <sub>SET</sub> /R <sub>WIN</sub> resistor insertion
Over power protection for channels 1, 3, 5 and 7	Yes		Output power limited to 20W max
Over power protection for channels 2, 4, 6 and 8	Yes		Output power limited to 10W max
Output hot wiring	Yes		
Suitable for luminaires with protection class	IEC Class I IEC Class II		
Set output current	R <sub>SET</sub>		See functional description. Default output current: 350 mA
Set output voltage window	R <sub>WIN</sub>		See functional description. OLED reference voltage: 9V
Constant lumen over lifetime	No		
OLED lifetime extension circuit	Yes		

**Note:** In case channel 1 is operated at a nominal output power above 9.5 Watt, channel 2 is disabled. This is implemented to guarantee the lifetime of the driver. This situation is also applicable on the channels 3 and 4, 5 and 6 and 7 and 8.

## Certificates and standards

Specification item	Value	Unit	Condition
Approval marks	ENEC, CE, UL, CQC		UL: E465448
Ingress Protection classification	IP20		
RoHS	Yes		2011/65/EU

## Inrush current

Specification item	Value	Unit	Condition
Inrush current $I_{PEAK}$	7	A	According IEC60555 Input voltage = 240 V <sub>AC</sub>
Half value time	900	μs	According IEC60555 Input voltage = 240 V <sub>AC</sub>
Inrush current $I_{PEAK}$	12	A	According NEMA410-2011 Input voltage = 120 V <sub>AC</sub>
Half value time	500	μs	According NEMA410-2011 Input voltage = 120 V <sub>AC</sub>
Inrush current $I_{PEAK}$	38	A	According NEMA410-2011 Input voltage = 277 V <sub>AC</sub>
Half value time	1100	μs	According NEMA410-2011 Input voltage = 277 V <sub>AC</sub>

## Operating window

For channel 1, 3, 5 and 7:

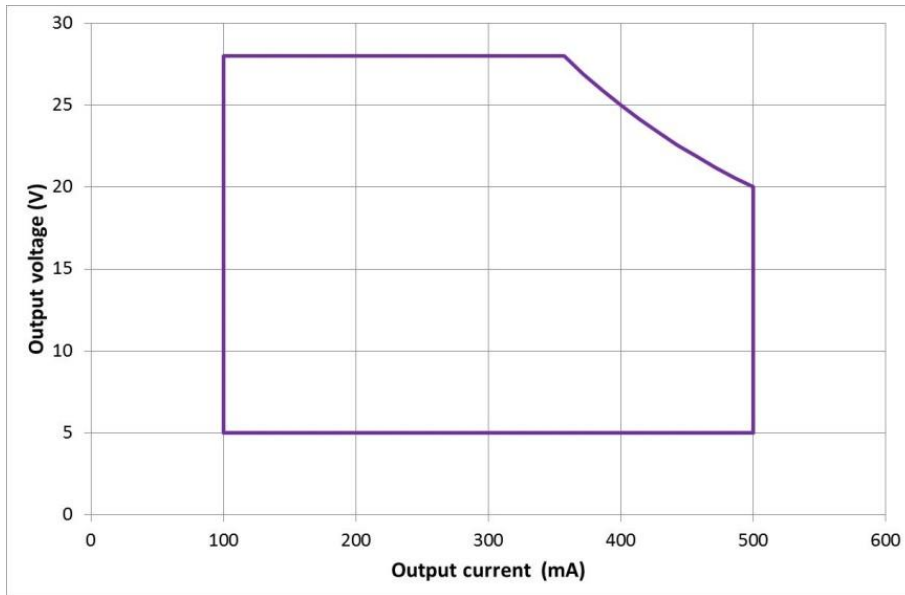

Figure 4: Operating window of channel 1, 3, 5 and 7 of Driver D230V 80W/0.1-0.5/1A/28V TD/A 8CH

For channel 2, 4, 6 and 8:

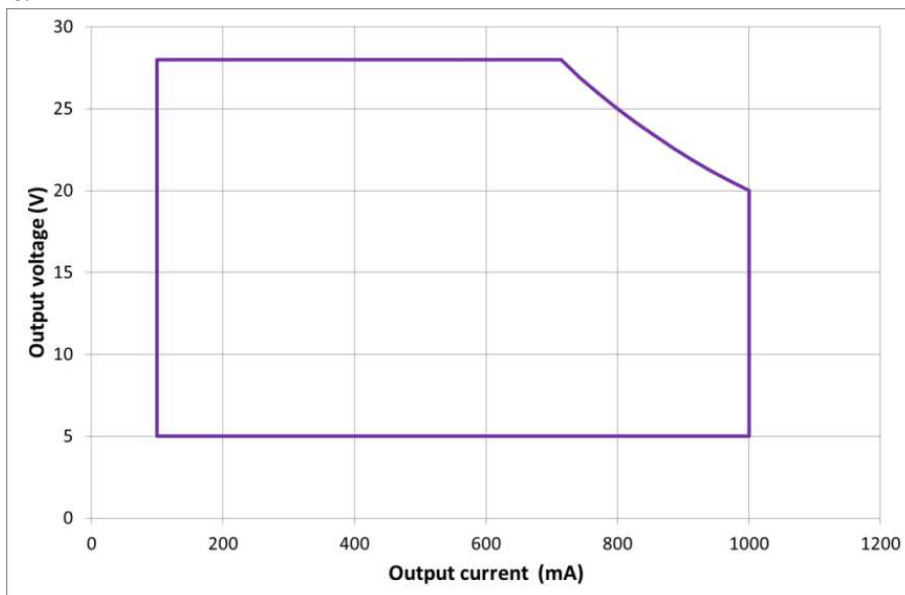

Figure 5: Operating window of channel 2, 4, 6 and 8 of Driver D230V 80W/0.1-0.5/1A/28V TD/A 8CH

### Efficiency versus mains voltage

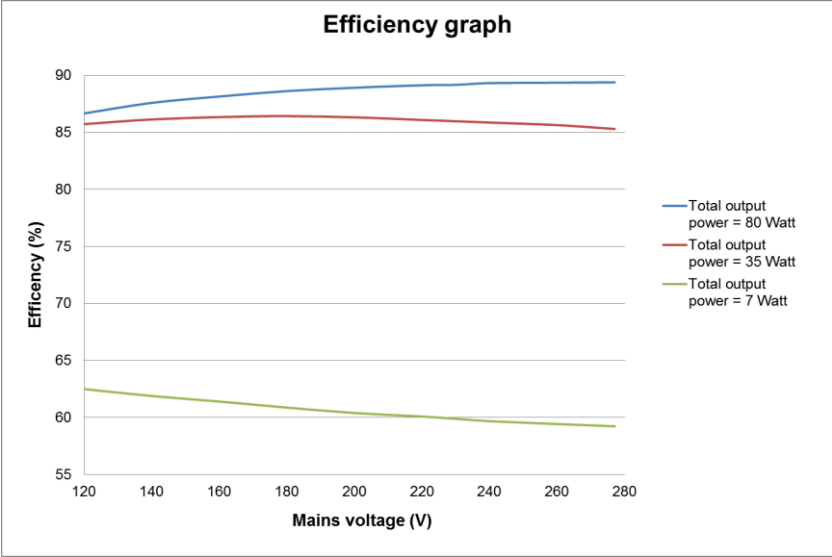

Figure 6: Efficiency graph of Driver D230V 80W/0.1-0.5/1A/28V TD/A 8CH



## Functional Description

The output current of each channel can be set with the external resistor  $R_{SET}$ . After switching on the mains voltage, the driver will start up and all connected OLEDs will light up. Each OLED can be connected via a Picoblade connector or by two loose wires. (Please respect the correct polarity of the OLED!)

The value of resistor  $R_{SET}$  to set the correct current of the OLED is depicted in the table below. In case the value is below 100 Ohm, the output channel will be disabled. For values above 3600 Ohm, the output is limited to 1000mA.

$R_{SET}$ [ $\Omega$ ]	$I_{SET}$ [mA]	$R_{SET}$ [ $\Omega$ ]	$I_{SET}$ [mA]	$R_{SET}$ [ $\Omega$ ]	$I_{SET}$ [mA]
0	100	330	204	1100	485
100	100	360	215	1200	515
110	105	390	228	1300	545
120	111	430	245	1500	602
130	116	470	261	1600	632
150	125	510	277	1800	684
160	130	560	297	2000	733
180	138	620	318	2200	780
200	146	680	340	2400	823
220	155	750	368	2700	883
240	166	820	392	3000	941
270	176	910	422	3300	993
300	190	1000	452	3600	1042

Table 1:  $R_{SET}$  table applicable for Driver D230V 80W/0.1-0.5/1A/28V TD/A 8CH

In case the  $R_{SET}$  value of channel 1 is higher than 1100 Ohm, channel 2 will be disabled. This situation is also applicable on the channels 3 and 4, 5 and 6 and 7 and 8.

With the resistor  $R_{WIN}$ , the OLED voltage protection level, the short-circuit protection trigger level and the end of lifetime (EOL) trigger level is set. The following table shows the value of  $R_{WIN}$  and the corresponding trigger levels.

Number of stack	$R_{WIN}$ [ $\Omega$ ]	$V_{OLED,ref}$ [V]	$V_{short}$ [V]	$V_{EOL}$ [V]
1	200	3	2	9
2	400	6	4	15
3	600	9	6	21
4	800	12	8	27
5	1000	15	10	33
6	1200	18	12	39
7	1400	21	14	45
8	1600	24	16	51
9	1800	27	18	57

Table 2:  $R_{WIN}$  table applicable for Driver D230V 80W/0.1-0.5/1A/28V TD/A 8CH

## Application setup

The power input terminals of this driver can be connected to a two-line 120, 220-240 or 277 Volt mains power grid. The driver allows 5 different operation modes.

- **Stand-alone (no dimming)**

In this mode, the driver can be switched on/off by the mains wall switch of the power grid. No further control connection is necessary.

- **Dimmable control via 0-10V**

In this mode, a 0-10V control gear or a 100k $\Omega$  potentiometer is connected to the 0-10V control input. The control input is suitable for Class I or Class 2 control gears.

The driver can be switched on/off by the mains wall switch of the power grid or by a control voltage below 0.5V. The output current can be set by a control voltage between 1V (min.) and 10V (max.)

A typical installation diagram is shown in figure 7.

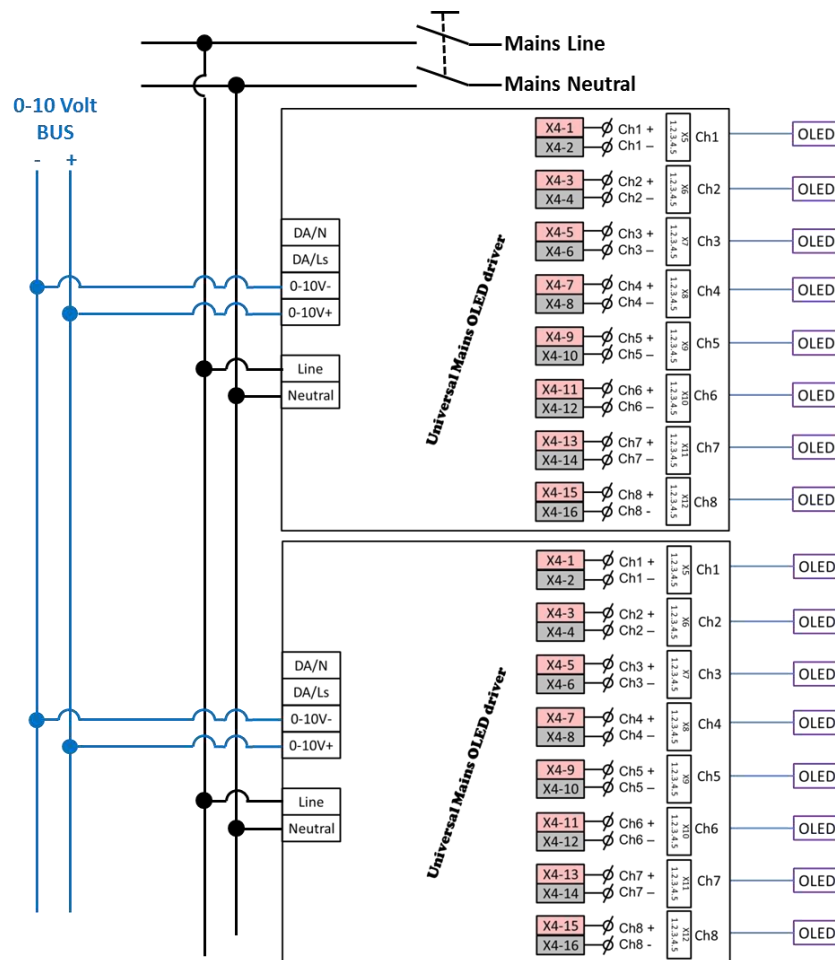

Figure 7: Typical 0-10V installation

## - Dimmable control via DALI

In this mode, a DALI control gear is connected to the DALI control input.

The control input is suitable for Class 1 or Class 2 control gears.

The driver can be switched on/off by the mains wall switch of the power grid or via DALI commands. The output current can be set different DALI dimming levels.

For more information on DALI, a Philips information website is available:

[http://www.lighting.philips.com/main/subsites/dynalite/library\\_support/technical\\_support/useful\\_information/dali\\_introduction.wpd](http://www.lighting.philips.com/main/subsites/dynalite/library_support/technical_support/useful_information/dali_introduction.wpd)

A typical installation is shown in figure 8.

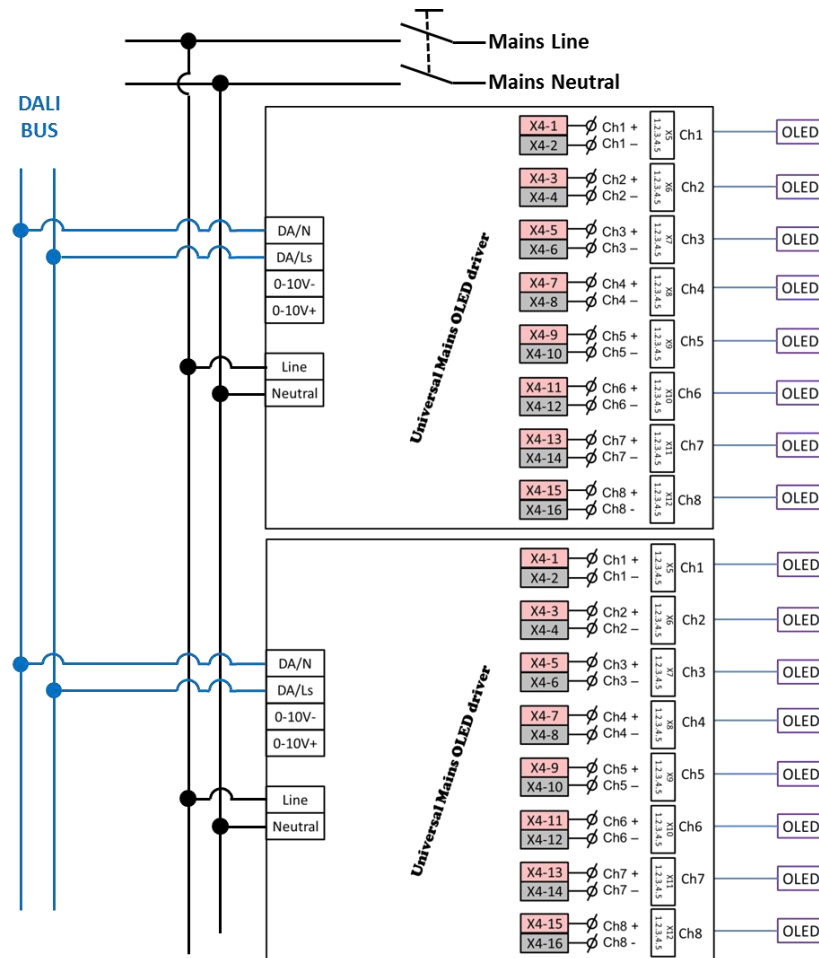

Figure 8: Typical DALI installation

### - Dimmable control via Touch and Dim

In this mode, a mains switch (TD) is connected between the Line of the power grid and the DA/Ls connector of the driver. The neutral of the power grid is connected at the DA/N connector. The insulation of the DA/Ls and DA/N is suitable to handle the mains voltages of the power grid.

The driver can be switched on/off by the mains wall switch of the power grid or by a short press (<0.5 seconds) on the TD switch. To dim the output currents, the TD switch should be pressed until the desired light level is reached. Each time the TD switch is pressed, the dimming direction (up or down) is changed. More details on which function is activated by the duration of pressing the button is depicted in table 3, a typical installation is shown in figure 9.

Command	Mode	Time (milliseconds)	Description
IGNORE	Touch and DIM	0 – 40	Do nothing
ON/OFF	Touch and DIM	40 – 500	Switch driver ON or OFF
DIM UP/DOWN	Touch and DIM	500 – 10000	Dim driver UP or DOWN
RESET	Touch and DIM	10000 – <b>Activation time</b>	Set dim level @ 37%, dim direction DOWN
Activation time	CORRIDOR	55000	Switch to CORRIDOR mode

Table 3: Touch and Dim functionality

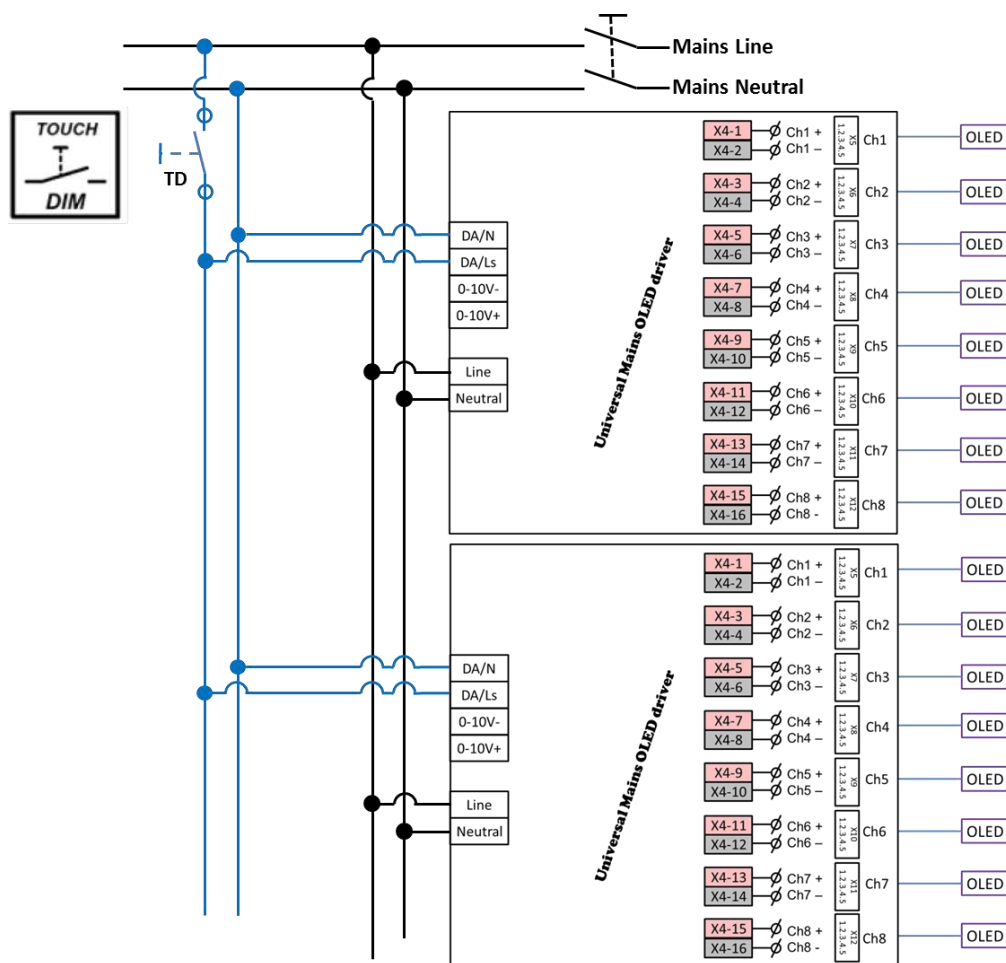

Figure 9: Typical Touch and Dim installation

## - Dimmable control via corridor function

In this mode, a momentary-action mains voltage switch (CS) is connected between the Line of the power grid and the DA/Ls connector of the driver. The neutral of the power grid is connected at the DA/N connector. The insulation of the DA/Ls and DA/N is suitable to handle the mains voltages of the power grid.

The corridor function can be activated by closing the voltage switch (CS) for more than 55 seconds.

The output current is controlled by the information received from the switch (CS).

To explain the functionality of the corridor function, the graph in figure 10 is used.

When in corridor mode and as long as there are mains cycles detected on the interface input (DA/Ls and DA/N), the driver will remain in configurable output “Normal Level” (A).

When there are no mains cycles detected anymore (B) at the interface input, the driver will keep the same output until the configurable delay time is expired.

After the adjustable delay time, the output is reduced to the configurable output “Background level” (C).

After the prolong time (which can be adjusted) the output will reduce to zero. The corridor function will be deactivated by off/on cycle on the mains input when the driver returns to the “Touch and Dim” mode.

The adjustable parameters of the corridor functionality are depicted in table 4 and a typical corridor installation is shown in figure 11.

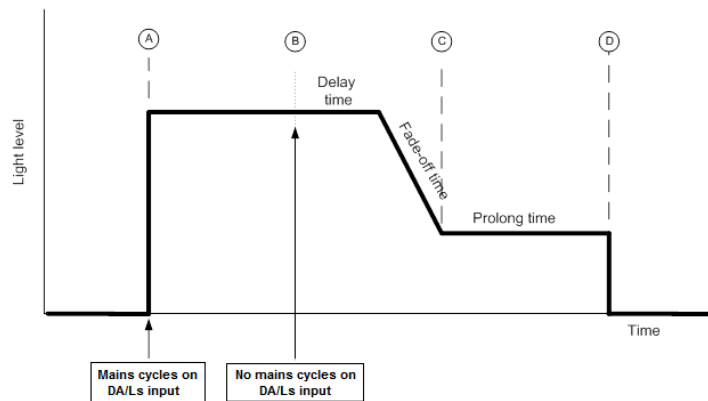

Figure 10: Control graph corridor function

Parameter	Value	Default	Remarks
Normal level	85 - 254	254	DALI levels (1 - 100%)
Background level	85 - 254	170	DALI levels (1 - 100%)
Fade time	0 - 65535	16000	DALI fade times (0 - 130 seconds)
Prolong time	0 - 255	30	0 – 254 minutes, 255 = infinitive
Corridor activate	0 - 65535	5500	0 - 655 seconds, 65535 = never
Mode	0, 1	0	0 = Touch and Dim, 1 = Corridor

Table 4: Corridor functionality table

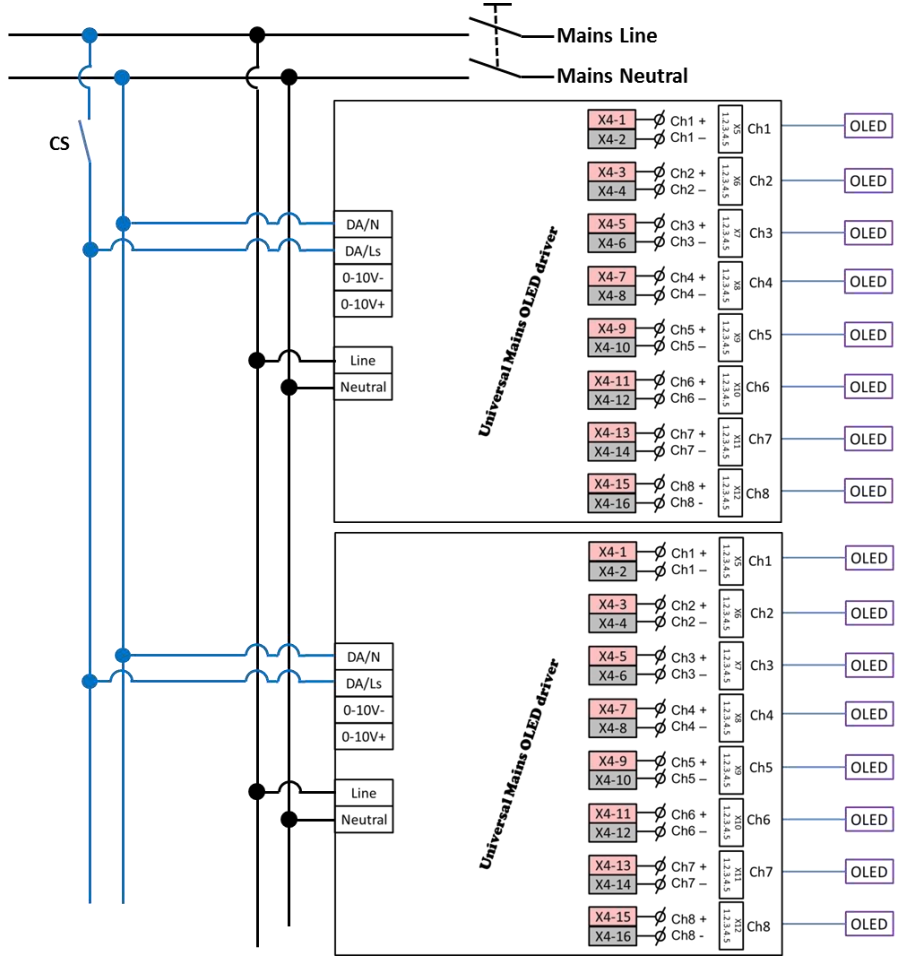

Figure 11: Typical Corridor function installation

## Dimming control with 0-10V

The following dimming curve is implemented in the 0-10 Volt dim interface:

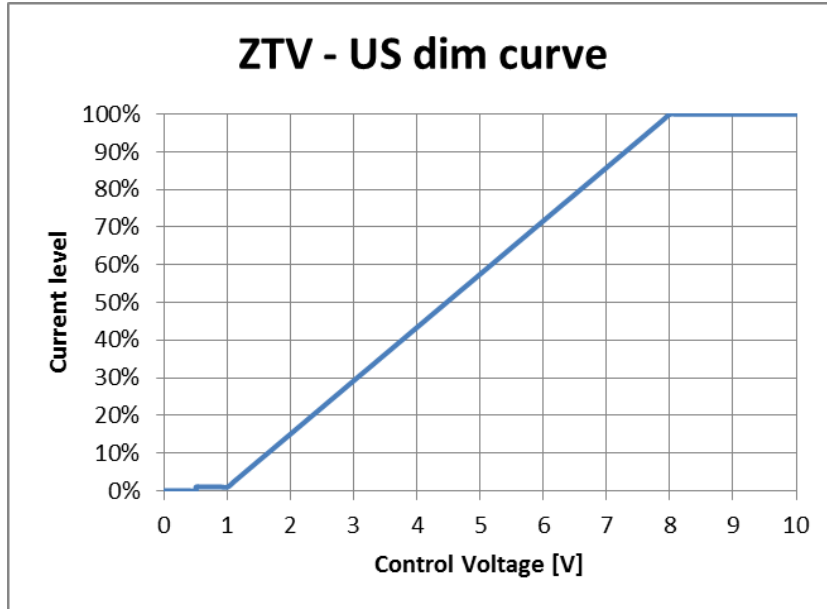

Figure 12: Linear dimming curve for 0-10V dimming

## Dimming control with DALI

The DALI interface has a higher priority over the 0-10V control interface, in case both control interfaces are connected, the output is set by the DALI interface information.

Two dimming curves are implemented which can be selected via DALI command:

### 1. Logarithmic dim curve (preset, acc. IEC62386-102)

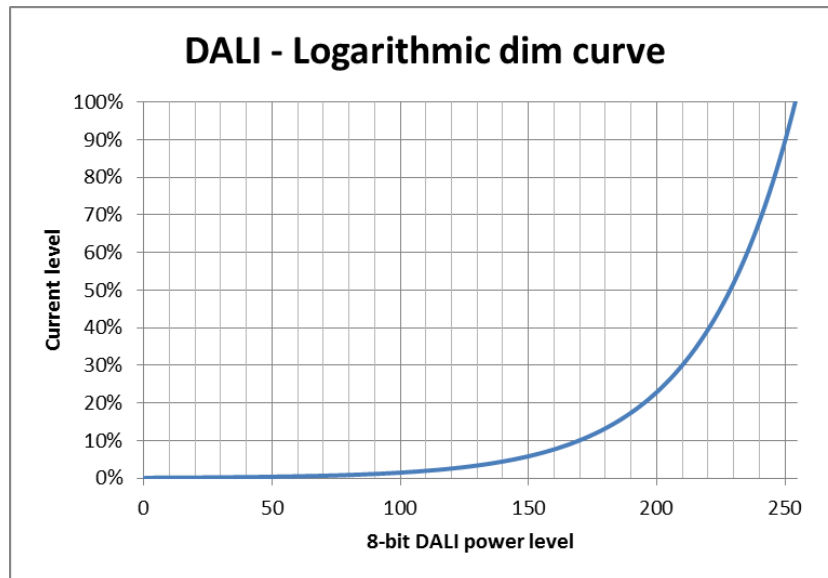

Figure 13: Logarithmic DALI dim curve

### 2. Linear dim curve

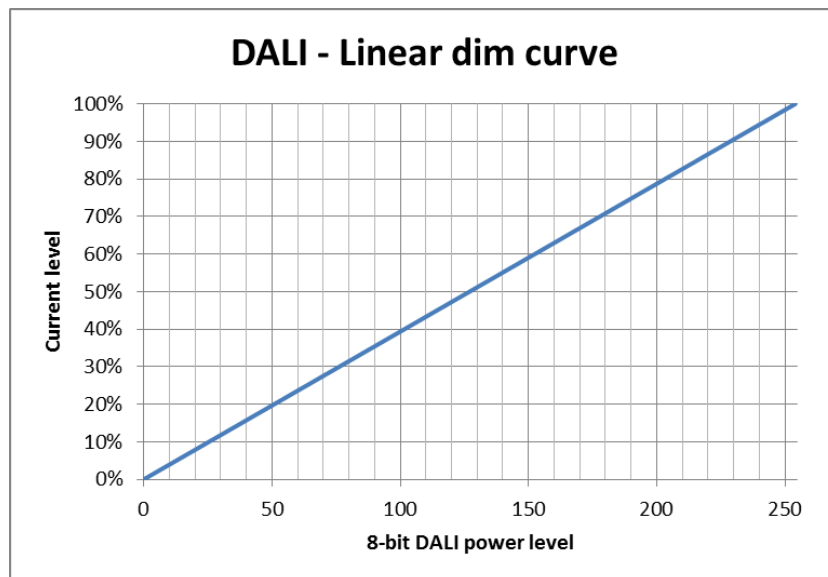

Figure 14: Linear DALI dim curve



## Application Information

### Programmable

OLED current and operating voltage window, dimming curves and Corridor functionality can be programmed by DALI interface by Philips MultiOne (9137 003 46703).

## Logistical data

Specification item	
Product name	Driver D230V 80W/0.1-0.5/1A/28V TD/A 8CH
Order code	37921130
Logistics code I2nc	9254 000 10201
EAN3	8727900379228
Pieces per box	10

#### Standards, compliance and sustainability

Philips Lumiblade products are environmentally friendly by avoiding the use of hazardous materials and by providing efficient illumination. These products are RoHS (EU directive 2011/65/EU) compliant.



#### Contact:

Philips GmbH  
Business Center OLED Lighting  
Philipsstr. 8, 52068 Aachen, Germany  
[info@lumiblade-experience.com](mailto:info@lumiblade-experience.com)

#### For more information visit:

[www.lumiblade-experience.com](http://www.lumiblade-experience.com)  
[www.facebook.com/lumiblade](https://www.facebook.com/lumiblade)  
[www.twitter.com/lumiblade](https://www.twitter.com/lumiblade)  
[www.youtube.com/user/PhilipsLumiblade](https://www.youtube.com/user/PhilipsLumiblade)



© 2014 Koninklijke Philips N.V.

All rights reserved. Reprint – in whole or in part – without permission is prohibited. Care has been taken to ensure that the information contained within is correct.